

# INSTALLATION MANUAL

**For crystalline solar photovoltaic modules**

**According with IEC61215 edition 2 & IEC61730 standards**

<b>1. Introduction</b>	
1.1 Purpose of the manual .....	2
1.2 Disclaimer of liability .....	2
1.3 Production identification.....	3
<b>2. Safety guidelines</b>	
2.1 General safety guidelines.....	3
2.2 Product precaution .....	4
2.3 Transport and storage safety guidelines .....	4
<b>3. Mechanical installation</b>	
3.1 Selecting the location .....	5
3.2 Selecting the proper supporting frame.....	5
3.3 Frame holes mounting.....	5
<b>4. Electrical mounting</b>	
4.1 Module selection.....	9
4.2 Safety factor .....	9
4.3 General installation .....	9
4.4 Grounding .....	10
<b>5. Commission and maintenance</b>	
5.1 Blocking diodes and bypass diode .....	10
5.2 Troubleshooting .....	10
5.3 Maintenance .....	11
<b>6. Technical data .....</b>	<b>11</b>

# 1 INTRODUCTION

## 1.1 PURPOSE OF THE MANUAL

This guide contains information on precautions to be used during the handling and installation of Talesun Solar Co., Ltd photovoltaic modules along with technical instructions to be followed during installation, mounting, wiring and maintenance thereof. Talesun Solar Co., Ltd hereafter is referred to as "Talesun". Any divergence from the contents of this manual during the handling, installation, or maintenance of Talesun's products will render the warranty and any guarantees there under null and void.

### Information for installers

- Installers must read and understand this manual before installation.
- Please ensure that installation, operation and maintenance of your photovoltaic system is only carried out by qualified persons able to carry out the technical procedures described in this manual, i.e. system planners, installers and maintenance personnel, and is carried out in accordance with all safety precautions in this manual and any and all applicable local codes. If you do not possess these qualifications, you may not carry out the work described herein except for cleaning.
- This manual and the instructions set forth herein are part of the product and should therefore be kept for the entire useful life of the solar installation.

### Information for operators

- Keep these instructions safe for the entire useful life of the solar installation.
- Please contact your plant supplier for information concerning the formal requirements for solar systems. Please be sure to learn about directives and permit requirements from the responsible local authorities and energy providers prior to installation of the solar plant.
- We recommend that you insure your solar system against natural hazards (e.g. against lightning strikes).

## 1.2 DISCLAIMER OF LIABILITY

- These instructions are only valid for products of Talesun.
- The information in this manual is based on Talesun's knowledge and experience and is believed to be reliable; but such information including product specification (without limitations) and suggestions do not constitute a warranty, expressed or implied. Talesun reserves the right to change the manual, the PV products, the specifications, or product information sheets without prior notice.
- Talesun assumes no liability for damage, loss, or expense arising out of or in any way connected with such installation, operation, use or maintenance. Talesun assumes no responsibility extending beyond the functional capability and safety of the modules.
- No license is granted by implication or otherwise under any patent or patent rights.
- If your questions are not adequately addressed in this manual, please first contact your system supplier. You can find more information on our website [www.talesun.com](http://www.talesun.com).

### 1.3 PRODUCTION IDENTIFICATION

Each module has three labels that provide the following information:

- **Nameplate:** describes the product type; rated power, rated current, rated voltage, open circuit voltage, short circuit current, all as measured under standard test conditions; weight, dimension etc.; the maximum system voltage is 1000 volts DC is shown on the nameplate. Maximum fuse rating is also shown.
- **“QA Pass” stamp:** module will be strictly inspected according to standard and get a QA Pass stamp on the backsheet.
- **2-dimensional Bar code:** The serial number has 16 digits. There are two bar codes on each module. One is permanently attached to the interior of the module and is visible when viewing the front of the module, and another is stuck to the rear side of the module.
- Removing a label will make the Talesun warranty void.



## 2 SAFETY GUIDELINES

### 2.1 GENERAL SAFETY GUIDELINES



**DANGER! Danger due to electric shock!** All installations must be performed in compliance with all applicable regional and local codes, or other national or international electrical standards as applicable.

- A solar module generates electricity and voltage even at low intensity of illumination.
- Physically disconnecting contacts in a live electrical circuit can cause arcing, resulting in grave or mortal injury. The severity increases when several modules are connected in series.
- Cover the solar modules with opaque material for the entire duration of assembly. Only then is the module reliably de-energized.
- Never disconnect plugs when under load. Be aware that even without the presence of daylight, residual charge may still be present in the plant. Ensure that the modules are first disconnected from the inverter prior to opening any contacts in the solar installation.
- Artificially concentrated sunlight shall not be directed on the module. Solar modules produce electrical energy when light shines on their front surface. The DC voltage may exceed 30V. Contact with a DC voltage of 30V or more is potentially hazardous.
- In the case of module or phase voltages of more than 120 V, the extra-low voltage range is left. Undertake the necessary protective and precautionary measures.
- Do not insert electrically conductive parts into the plugs and junction box. Do not touch the contacts or exposed terminals.
- Keep children and unauthorized persons away from the modules.
- In case of damaged modules or operational errors of the solar array, always contact your installer or Talesun Technical Customer Service.
- Do not wear metallic ornaments or metallic devices while installing or troubleshooting photovoltaic systems.



**WARNING! Danger of injury due to broken glass! Risk of injury due to falling modules!**

The modules are primarily made of glass and must therefore be handled with appropriate caution.

- In order to ensure safe mounting, familiarize yourself with all applicable national regulations for work safety and accident prevention.
- Wear suitable protective clothing (e.g. safety shoes, protective gloves) in order to prevent injuries.
- If the front glass is broken, or the back sheet is torn, contact with any module surface or the frame can cause electric shock.

## 2.2 PRODUCT PRECAUTION

- Do not attempt to disassemble the modules.
- Do not remove any attached nameplates or components from the modules.
- Do not open the junction box under any circumstances.
- Only carry out modifications to the modules that have been confirmed by Talesun in writing in advance.
- Do not carry out any extra drilling (e.g. for fasteners) on the modules.
- Use only insulated tools that are approved for work on electrical installations.
- Do not use light concentrators (e.g. mirrors or lenses) to attempt to increase the capacity of the module. The module may be damaged. This also voids the warranty.



## 2.3 TRANSPORT AND STORAGE SAFETY GUIDELINES

Inappropriate transport and installation may break the module.

To prevent damage of the modules:

- Transport the modules in their original packaging until installation.
- Store the modules securely in cool and dry rooms.  
The packaging is not weather-resistant!
- Protect the modules against scratches and other damage, especially from impact at the edges or improper storage.
- Ensure modules do not bow under their own weight.
- Do not rest a module unprotected on its edges. This can damage the module and the frame.
- Do not lift or move the modules using the cables or at the junction box under any circumstances!
- Do not set the modules down hard on any surface.
- Do not subject the module surfaces to mechanical stress.
- Do not stand on the modules.
- Do not drop or place objects on the modules.

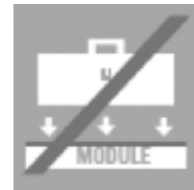

## 3 MECHANICAL INSTALLATION

### 3.1 SELECTING THE LOCATION

- The modules are certified according to the norm IEC 61215 and others for safe operation in moderate climates.
- Do not expose the modules to chemicals.
- Do not place the modules in standing water. The junction box is splash-proof only.
- Do not install the modules near flammable gases and vapors (e.g. gas containers) or near open flames and flammable materials. Solar modules are not explosion-proof operating equipment.
- If there is exposure to salt (i.e., marine environments) and sulfur (i.e., sulfur sources, volcanoes), there is a risk of corrosion.
- A module is considered shade-free when it is entirely unshaded throughout the year (e.g. by buildings, chimneys, trees). Even partial shading of the modules (e.g. by overhead lines, dirt, snow) should be avoided.

### 3.2 SELECTING THE PROPER SUPPORT FRAME

Always observe the instructions and safety precautions included with the support frames to be used with the modules. Install each module to a mounting structure:

- That is made of durable, corrosion-resistant and UV-resistant material.
- That can transfer forces on the module to the assembly substructure.
- That ensures that no mechanical stress (e.g. caused by vibrations, twisting or expansion) is generated on the module.
- That ensures sufficient back ventilation of the module.
- That ensures long term stability.
- That will not give rise to galvanic corrosion in case of direct metal contact (i.e. grounding lead, screws, washers, etc.)
- That allows for strain-free expansion and contraction due to natural ambient temperature variations.

### 3.3 MOUNTING

Modules connected in series should be installed at the same orientation and angle. Different orientations or angles may cause a loss of power output due to the change in sunlight exposure.

- When developing the final layout of photovoltaic system, consider keeping suitable access to allow the maintenance and inspection works. To minimize risk in the event of an indirect lightning strike, avoid forming loops when designing the system.
- The modules may be installed in landscape or portrait format.
- Install the module in such a way that the junction box is positioned in the upper area of the module and the wires hang downwards.
- The optimal tilt angle of the module depends on the respective latitude. We recommend a photovoltaic simulation tool to ensure the optimal orientation.

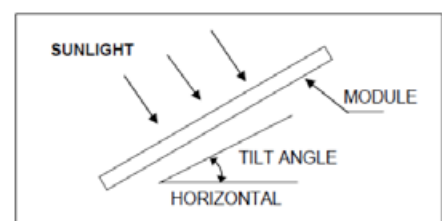

## Ground mount

- Select the height of the mounting system to prevent the lowest edge of the module from being covered by snow for a long time in winter in areas that experience heavy snowfalls.
- In addition, assure the lowest portion of the module is placed high enough so that it is not shaded by plants or trees or damaged by sand and stones driven by wind.

## Roof mount

- When installing a module on a roof or building, ensure that it is securely fastened and cannot fall as a result of wind or snow loads.
- Provide adequate ventilation under a module for cooling; the recommended standoff height is 10 cm. Clearance of 1/4 of an inch (6.35 mm) or more between modules is required to allow for thermal expansion of the frames.
- For roof mounting applications the assembly is to be mounted over a fire resistant roof covering rated for the application. Talesun modules have been listed as Class C according to UL790 standard.
- Any roof penetration required to mount the module must be properly sealed to prevent leaks.
- In some cases, a special support frame may be necessary.
- The roof installation of solar modules may affect the fireproofing of the building construction.
- Do not install modules on a roof or building during strong winds to prevent accidents.
- All module support structures used to support PV modules at correct tilt angles should be wind and snow load rated by appropriate local and civil codes prior to installation.

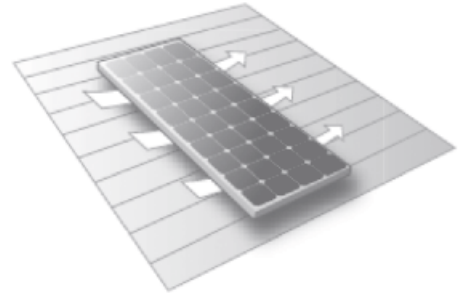

## Pole mount

- When installing a module on a pole, choose a pole and module mounting structure that will withstand anticipated winds for the area.

### Method A: Frame Holes Mounting

Modules must be securely attached to the mounting structure using four pre-drilled mounting holes in the frame.

- Modules should be bolted to support structures through mounting holes located in the frame's back flanges only. Do not drill additional holes. Doing so will void the warranty.
- Each module must be securely fastened at a minimum of 4 points. If additional wind or snow loads are anticipated for this installation, additional mounting points should be used. System designer and installer are responsible for load calculations and for proper design of support structure.
- Use appropriate corrosion-proof fastening materials. All mounting hardware (bolt/spring washer/flat washer/nut) should be stainless steel M8 size.
- Follow mounting guidelines recommended by the PV mounting supplier. The mounting design must be certified by a registered professional engineer.
- The mounting design and procedures shall comply with local codes and all authorities having jurisdiction.
- Use a torque wrench for installation. Tightening torques should be within 10~17 Nm for M8 coarse thread bolts, depending on bolt quality class.

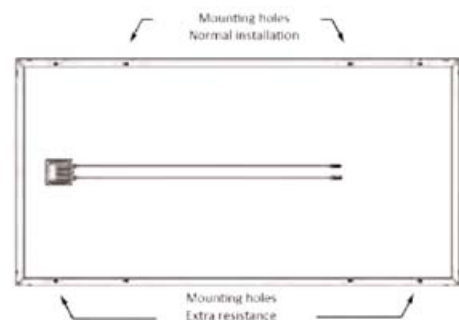

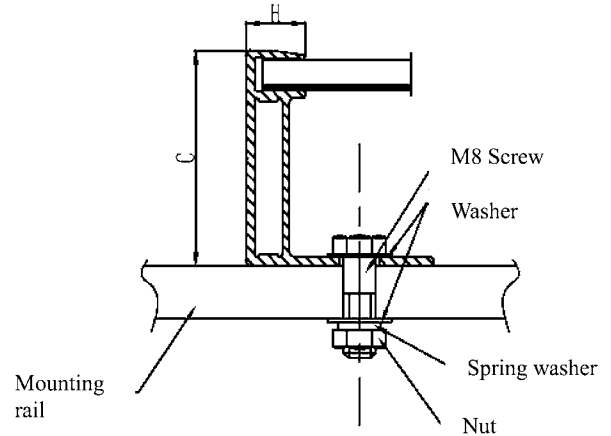
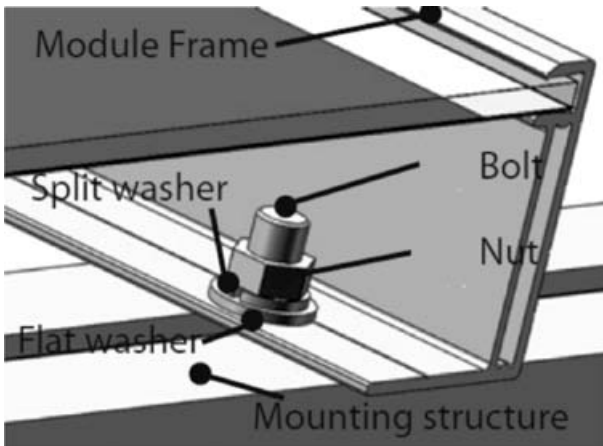

### Method B: Clamping installation

- Modules can be installed with clamps. Modules must be securely attached to the mounting structure with four clamps on the short frame.
- The modules must be properly secured to their support so that they can withstand live load conditions, including wind uplift, to the pressure they have been certified for. It's the installer's responsibility to ensure the clamps used to secure the module are strong enough.
- The modules are not subject to wind or snow loads exceeding the maximum permissible loads.
- The module clamps which are used must not come in contact with the front glass and must not deform the frame. Avoid shadowing effects from the module clamps. Drain holes in the module frame must not be closed or obscured by the clamps.
- The module installed with clamps on the short frame for 2400 Pa (see the following picture).

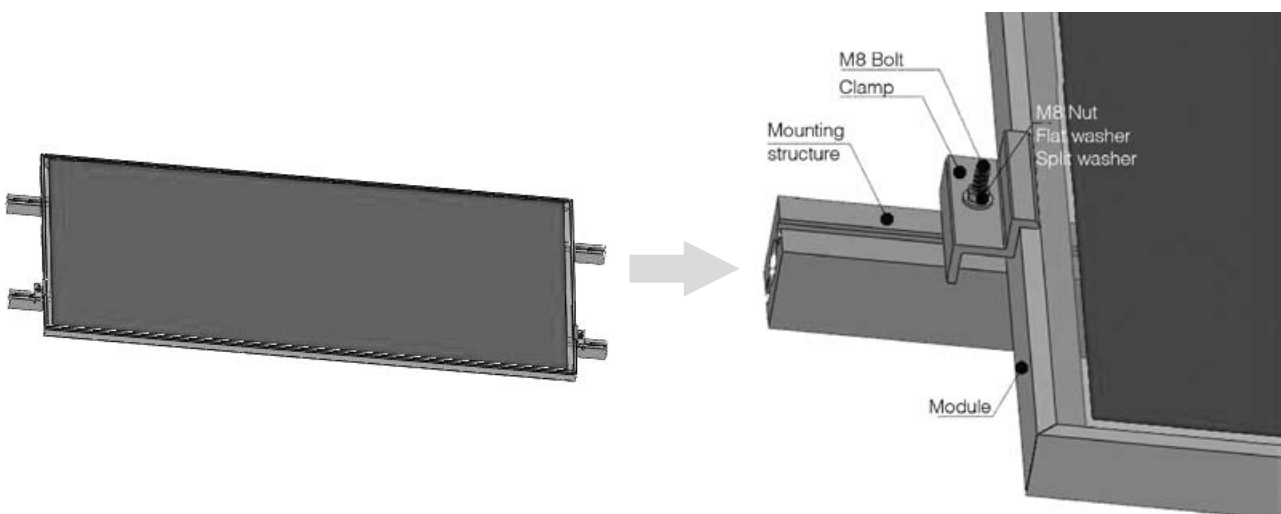
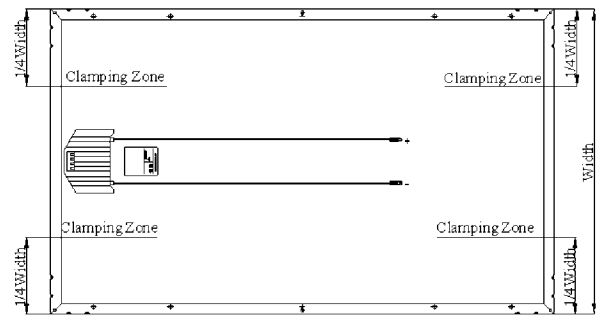

- Use four clamps on the short frame, and the clamping zone is from module edge to 1/4 width of the short frame.
- Use a torque wrench for installation, and the compression for each clamps is not strong to avoid potential damages to module frames. The recommended maximum compression for each clamp is 20MPa (2900PSI).
- The module mounting structure must be made of durable, corrosion-resistant and UV-resistant material. All mounting hardware (bolt/flat washer/split washer/nut) should be stainless steel M8 size.
- The minimum recommended length for each clamp is 50mm.
- The modules have been designed to resist a static load of 2400Pa, and the resistance value can decrease if modules are not mounted following the instruction above.

### METHOD C: INSERT MOUNTING

Fringe side installation

Middle modules installation

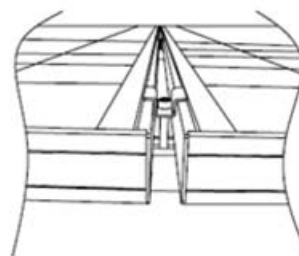
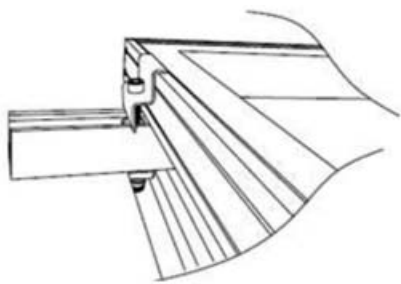

The movement of the mounting rail and the clamps center line are recommended to be within the black arrow area.

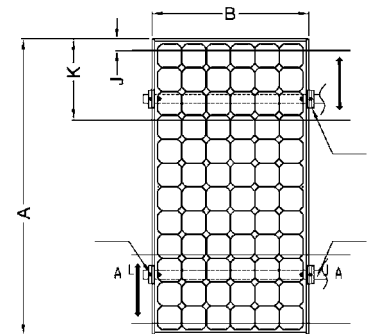
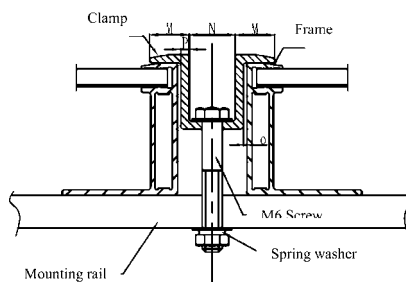
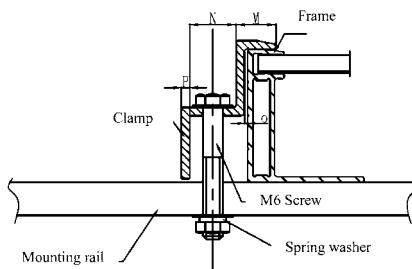

module type	Cell type	Cell Q'ty	Dimensions (mm)						
			A*B	J	K	M	N	O*	P*
TP672 Series	6inch crystalline (M/P)	6*12	1960*990	50	600	12	20	0.5~2	2.5~3
TP660 Series	6inch crystalline (M/P)	6*10	1640*990	50	425	12	20	0.5~2	2.5~3
TP654 Series	6inch crystalline (M/P)	6*9	1482*990	50	380	12	20	0.5~2	2.5~3
TP636 Series	6inch crystalline (P)	4*9	1482*672	50	380	12	20	0.5~2	2.5~3
TP596 Series	5inch crystalline (M)	8*12	1580*1064	50	416	12	20	0.5~2	2.5~3
TP572 Series	5inch crystalline (M)	6*12	1580*808	50	416	12	20	0.5~2	2.5~3
TP536 Series	5inch crystalline (M)	4*9	1199*551	50	320	12	20	0.5~2	2.5~3

Table 1: Mechanical dimensions when modules installed at portrait orientation with Clamp fitting method

\*Notes: "672" represents 72pcs 6inch cell, etc.

Dimension "O" represents the distance between clamp and frame. / Dimension "P" represents the thickness of clamp.

### WATER RUNOFF

- Ensure that the drainage openings of the frame are left open following installation to allow water runoff. This prevents frost damage. Install the module in such a way that rainwater and snowmelt can run off freely to avoid standing water or puddling.



## WIND/SNOW LOAD

- The modules have been designed to resist a static load of 5400 Pa (positive load).
- When using an insertion system on a short frame without additional support-rail, the modules have been designed to resist a static load of 2400 Pa.
- This resistance value can decrease if modules are not mounted following the instructions above.

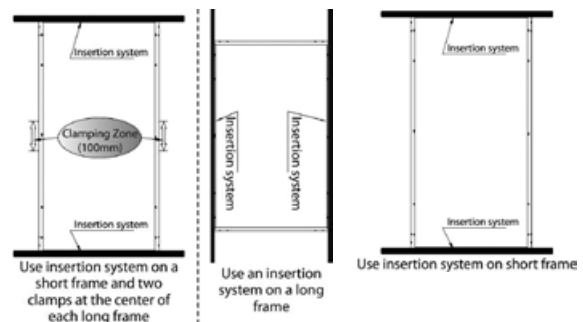

## 4 Electrical installation

### 4.1 MODULE SELECTION

Only connect modules of the same type, same configurations and same power class in the same system. This is the only way to achieve optimal yields.

### 4.2 SAFETY FACTOR

Under normal conditions, a photovoltaic module may experience conditions that produce more current and/or voltage than reported at Standard Test Conditions. Accordingly, the values of ISC and VOC marked on modules should be multiplied by a factor of 1.25 when determining component voltage ratings, conductor capacities, fuse sizes and size of controls connected to the module output. Alternatively, all valid national regulations for the installation of electrical systems are to be applied.

### 4.3 GENERAL INSTALLATION

- Before installing modules, contact the appropriate authorities to determine permissions, installation and inspection requirements to follow that apply to your site and installation.
- Check applicable building codes to ensure that the construction or structure (roof, facade, support, etc.) where the modules are being installed is strong enough to support the weight of the modules and all other system components.
- If modules are connected in series, the total voltage is equal to the sum of individual voltages. The recommended max. number of module (N) =  $V_{\text{max system}} / [V_{\text{oc(at STC)}}] / 1.25$ .
- If the modules are allowed to be installed in parallel electrically, each module (or series string of modules so connected) shall be provided with the maximum series fuse as specified. For applications requiring high currents, several photovoltaic modules can be connected in parallel; the total current is equal to the sum of individual currents, each module (or series string of modules so connected) shall be provided with the maximum series fuse as specified. The recommended number of module in parallel is only one.
- Use special solar cable and suitable plugs only (wiring should be placed in conduit that is sunlight-resistant or, if exposed, should be sunlight-resistant) in accordance with local fire, building and electrical codes. Ensure that they are in perfect electrical and mechanical condition.
- Only use solar cables as connection cables. Use connectors of the same type and manufacturer within a solar system, and compatible connectors to connect the inverter.
- Ensure that all electrical components are in a proper, dry and safe condition. In this way you avoid electrical short-circuits or dangerous contact voltages due to defective or damaged cables.
- Always avoid mechanical stressing of the connection cables.
- Ensure a tight connection between the individual connectors (especially to the inverter). Make sure they click together properly.

#### 4.4 GROUNDING:

- Although the modules are certified to safety class II, it is recommended that they be grounded and the module installation complies with all local electrical codes and regulations.
- The earth grounding connection should be made by a qualified electrician.
- Connect module frames to each other using adequate grounding cables (recommended size 4-14 mm<sup>2</sup>, copper wires).
- The bolts, nuts, flat washers, lock washers or other relevant hardware should be made with stainless steel.
- Other grounding methods can be acceptable, provided they comply with all local electrical codes and regulations.
- If the support frame is made of metal, the surface of the frame must be electroplated and have excellent conductivity.



A grounding kit with M4 size SS cap bolt, M4 size SS flat washer, M4 size SS cup washer and M4 size SS nut with teeth is used to attach a copper grounding hole on the frame. Attach the wire between the flat washer and the cup washer. Ensure the cup washer is between the frame and wire with concave side up to prevent corrosion due to dissimilar metal. Tighten the bolt securely using the SS nut with teeth. A wrench may be used in this application. The tightening torque is 1 Nm.

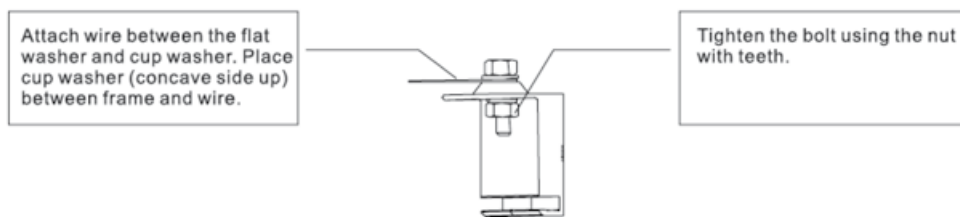

## 5 COMMISSION AND MAINTENANCE

### 5.1 BLOCKING DIODES AND BYPASS DIODE

- Blocking diodes prevent current flowing from the battery to the module when no electricity is being generated. It is recommended to use blocking diodes when a charging regulator is not used. Your specialist dealer can advise you regarding the suitable types.
- In systems with more than two modules in series, high reverse current can flow through cells that are shaded partially or outright when part of a module is shaded and the rest is exposed to the sun. These currents can cause the affected cells to get very hot and could even damage the module. To protect module from such high reverse currents, by-pass diodes are used in modules. All modules rated greater than 55 Watt have bypass diodes already integrated in the junction box. In the unlikely event of diode failure, it can be easily replaced; however, doing so will void warranty unless this exchange is made by an authorized person.
- Protect yourself from electric shocks while debugging or maintaining the solar power system.

### 5.2 TROUBLESHOOTING



#### **DANGER! Life danger due to electric shock!**

- Please do not attempt to correct problems on your own!
- In case of problems or damaged modules (for example, glass breakage, damaged cables) please contact your installer or the Talesun Technical Customer Service.

## 5.1 MAINTENANCE

Talesun modules are built to last and require minimal maintenance. The dirt is typically washed away by rain. However, rain may not adequately clear more stubborn grime (i.e. pollen, vegetation, bird droppings, etc.). Such soiling which shades the active area of the module can lead to a reduction in the system's performance. Talesun recommends the following maintenance in order to ensure optimum performance of the module:

- Clean the glass surface of the module as necessary. Always use water and a soft sponge or cloth for cleaning. A mild, non-abrasive cleaning agent can be used to remove stubborn dirt.
- Check the electrical and mechanical connections every six months to verify that they are clean, secure and undamaged.
- If any problem arises, have them investigated by a competent specialist. Attention: observe the maintenance instructions for all components used in the system, such as support frames, charging regulators, inverters, batteries etc.

## 6 Technical data

Module Type	TP672M-*** TP672M-***B	TP660M-*** TP660M-***B	TP654M-*** TP654M-***B	
Power Level	***=265-315 in increment of 5	***=215-265 in increment of 5	***=195-235 in increment of 5	
Type	6inch/72cells/ Multi-crystalline	6inch/60cells/ Multi-crystalline	6inch/54cells/ Multi-crystalline	
Dimension [mm]	1960*990	1640*990	1482*990	
Weight [kg]	26	20	17	

Module Type	TP672P-*** TP672P-***B	TP660P-*** TP660P-***B	TP654P-*** TP654P-***B	TP636P-*** TP636P-***B
Power Level	***=260-315 in increment of 5	***=210-260 in increment of 5	***=190-230 in increment of 5	***=130-150 in increment of 5
Type	6inch/72cells/ Mono-crystalline	6inch/60cells/ Mono-crystalline	6inch/54cells/ Mono-crystalline	6inch/36cells/ Multi-crystalline
Dimension [mm]	1960*990	1640*990	1482*990	1199*551
Weight [kg]	26	20	17	15

Module Type	TP596M-***	TP572M-*** TP572M-***B	TP536M-*** TP536M-***B	
Power Level	***=230-275 in increment of 5	***=170-205 in increment of 5	***=85-105 in increment of 5	
Type	5inch/96cells/ Mono-crystalline	5inch/72cells/ Mono-crystalline	5inch/36cells/ Mono-crystalline	
Dimension [mm]	1580*1064	1580*808	1482*672	
Weight [kg]	21	15	10	

Flammability rating	C
Application class	A
Static load [Pa]	2400/5400

Model	Maximum System Voltage (V)	Pmax (W)	Vmpp (V)	Impp (A)	Voc (V)	Isc (A)	Fuse Rating (A)
TP672M-315;	1000(IEC)	315	37.3	8.45	46.0	8.87	15
TP672M-310; TP672M-310B	1000(IEC)	310	36.9	8.40	45.8	8.83	
TP672M-305; TP672M-305B	1000(IEC)	305	36.5	8.36	45.5	8.79	
TP672M-300; TP672M-300B	1000(IEC)	300	36.1	8.32	45.2	8.75	
TP672M-295; TP672M-295B	1000(IEC)	295	35.9	8.22	44.9	8.70	
TP672M-290; TP672M-290B	1000(IEC)	290	35.8	8.11	44.7	8.65	
TP672M-285; TP672M-285B	1000(IEC)	285	35.7	7.99	44.5	8.59	
TP672M-280; TP672M-280B	1000(IEC)	280	35.5	7.89	44.3	8.53	
TP672M-275; TP672M-275B	1000(IEC)	275	35.3	7.80	44.1	8.46	
TP672M-270; TP672M-270B	1000(IEC)	270	35.1	7.70	43.9	8.39	
TP672M-265;	1000(IEC)	265	34.9	7.59	43.7	8.31	

TP660M-265;	1000(IEC)	265	30.6	8.66	37.9	8.95	15
TP660M-260; TP660M-260B	1000(IEC)	260	30.4	8.55	37.7	8.83	
TP660M-255; TP660M-255B	1000(IEC)	255	30.2	8.44	37.5	8.81	
TP660M-250; TP660M-250B	1000(IEC)	250	30.1	8.31	37.3	8.78	
TP660M-245; TP660M-245B	1000(IEC)	245	30.0	8.17	37.2	8.69	
TP660M-240; TP660M-240B	1000(IEC)	240	29.8	8.06	37.0	8.62	
TP660M-235; TP660M-235B	1000(IEC)	235	29.6	7.94	36.9	8.54	
TP660M-230; TP660M-230B	1000(IEC)	230	29.5	7.80	36.8	8.45	
TP660M-225; TP660M-225B	1000(IEC)	225	29.3	7.68	36.6	8.39	
TP660M-220; TP660M-220B	1000(IEC)	220	28.9	7.61	36.5	8.33	
TP660M-215; TP660M-215B	1000(IEC)	215	28.6	7.52	36.3	8.25	

TP654M-235; TP654M-235B	1000(IEC)	235	27.3	8.61	34.5	8.86	15
TP654M-230; TP654M-230B	1000(IEC)	230	27.1	8.49	34.3	8.78	
TP654M-225; TP654M-225B	1000(IEC)	225	26.9	8.43	34.1	8.68	
TP654M-220; TP654M-220B	1000(IEC)	220	26.7	8.24	33.9	8.60	
TP654M-215; TP654M-215B	1000(IEC)	215	26.5	8.11	33.7	8.51	
TP654M-210; TP654M-210B	1000(IEC)	210	26.3	8.00	33.6	8.38	
TP654M-205; TP654M-205B	1000(IEC)	205	26.1	7.85	33.4	8.26	
TP654M-200; TP654M-200B	1000(IEC)	200	25.9	7.72	33.2	8.17	
TP654M-195; TP654M-195B	1000(IEC)	195	25.7	7.59	33.0	8.09	

Model	Maximum System Voltage (V)	Pmax (W)	Vmpp (V)	Imp (A)	Voc (V)	Isc (A)	Fuse Rating (A)
TP672P-315;	1000(IEC)	315	36.6	8.61	45.4	9.17	15
TP672P-310;	1000(IEC)	310	36.4	8.52	45.2	9.09	
TP672P-305;	1000(IEC)	305	36.2	8.43	45.0	8.99	
TP672P-300; TP672P-300B	1000(IEC)	300	36.0	8.33	44.8	8.90	
TP672P-295; TP672P-295B	1000(IEC)	295	35.8	8.24	44.5	8.82	
TP672P-290; TP672P-290B	1000(IEC)	290	35.6	8.15	44.3	8.75	
TP672P-285; TP672P-285B	1000(IEC)	285	35.4	8.05	44.1	8.67	
TP672P-280; TP672P-280B	1000(IEC)	280	35.3	7.94	44.0	8.58	
TP672P-275; TP672P-275B	1000(IEC)	275	35.2	7.82	43.8	8.48	
TP672P-270; TP672P-270B	1000(IEC)	270	35.0	7.72	43.7	8.40	
TP672P-265; TP672P-265B	1000(IEC)	265	34.9	7.60	43.6	8.31	
TP672P-260; TP672P-260B	1000(IEC)	260	34.7	7.50	43.5	8.21	

TP660P-260;	1000(IEC)	260	30.6	8.50	37.7	8.85	15
TP660P-255; TP660P-255B	1000(IEC)	255	30.4	8.39	37.5	8.73	
TP660P-250; TP660P-250B	1000(IEC)	250	30.3	8.25	37.3	8.69	
TP660P-245; TP660P-245B	1000(IEC)	245	30.1	8.14	37.1	8.65	
TP660P-240; TP660P-240B	1000(IEC)	240	29.7	8.08	36.9	8.62	
TP660P-235; TP660P-235B	1000(IEC)	235	29.5	7.97	36.8	8.59	
TP660P-230; TP660P-230B	1000(IEC)	230	29.4	7.83	36.7	8.52	
TP660P-225; TP660P-225B	1000(IEC)	225	29.2	7.71	36.6	8.40	
TP660P-220; TP660P-220B	1000(IEC)	220	29.0	7.59	36.4	8.32	
TP660P-215; TP660P-215B	1000(IEC)	215	28.7	7.49	36.1	8.20	
TP660P-210; TP660P-210B	1000(IEC)	210	28.5	7.38	36.0	8.10	

TP654P-230; TP654P-230B	1000(IEC)	230	27.2	8.46	34.3	8.75	15
TP654P-225; TP654P-225B	1000(IEC)	225	27.0	8.33	34.1	8.66	
TP654P-220; TP654P-220B	1000(IEC)	220	26.8	8.21	33.9	8.57	
TP654P-215; TP654P-215B	1000(IEC)	215	26.6	8.08	33.7	8.48	
TP654P-210; TP654P-210B	1000(IEC)	210	26.4	7.96	33.6	8.40	
TP654P-205; TP654P-205B	1000(IEC)	205	26.2	7.82	33.4	8.29	
TP654P-200; TP654P-200B	1000(IEC)	200	26.0	7.69	33.2	8.17	
TP654P-195; TP654P-195B	1000(IEC)	195	25.8	7.55	33.0	8.05	
TP654P-190; TP654P-190B	1000(IEC)	190	25.7	7.39	32.8	7.93	

Model	Maximum System Voltage (V)	Pmax (W)	Vmpp (V)	Impp (A)	Voc (V)	Isc (A)	Fuse Rating (A)
TP636P-150; TP636P-150B	1000(IEC)	150	18.0	8.33	22.7	8.78	15
TP636P-145; TP636P-145B	1000(IEC)	145	17.8	8.15	22.5	8.61	
TP636P-140; TP636P-140B	1000(IEC)	140	17.7	7.91	22.4	8.43	
TP636P-135; TP636P-135B	1000(IEC)	135	17.5	7.71	22.1	8.31	
TP636P-130; TP636P-130B	1000(IEC)	130	17.4	7.47	21.9	8.14	

TP596M-275;	1000(IEC)	275	49.4	5.57	60.8	5.90	10
TP596M-270	1000(IEC)	270	49.2	5.49	60.6	5.81	
TP596M-265	1000(IEC)	265	48.9	5.41	60.4	5.77	
TP596M-260	1000(IEC)	260	48.7	5.32	60.1	5.71	
TP596M-255	1000(IEC)	255	48.4	5.27	59.8	5.66	
TP596M-250	1000(IEC)	250	47.9	5.21	59.5	5.58	
TP596M-245	1000(IEC)	245	47.6	5.13	59.1	5.51	
TP596M-240	1000(IEC)	240	47.2	5.09	58.8	5.48	
TP596M-235	1000(IEC)	235	46.8	5.02	58.6	5.46	
TP596M-230	1000(IEC)	230	46.5	4.95	58.2	5.39	

TP572M-210; TP572M-210B	1000(IEC)	210	38	5.53	45.8	5.83	10
TP572M-205; TP572M-205B	1000(IEC)	205	37.9	5.41	45.5	5.79	
TP572M-200; TP572M-200B	1000(IEC)	200	37.6	5.32	45.3	5.72	
TP572M-195; TP572M-195B	1000(IEC)	195	37.0	5.28	45.1	5.63	
TP572M-190; TP572M-190B	1000(IEC)	190	36.5	5.21	45.0	5.56	
TP572M-185; TP572M-185B	1000(IEC)	185	35.8	5.17	44.8	5.48	
TP572M-180; TP572M-180B	1000(IEC)	180	35.4	5.09	44.6	5.40	
TP572M-175; TP572M-175B	1000(IEC)	175	35.3	4.96	44.5	5.34	
TP572M-170; TP572M-170B	1000(IEC)	170	35.2	4.83	44.4	5.29	

TP536M-105; TP536M-105B	1000(IEC)	105	19.0	5.53	22.8	5.86	10
TP536M-100; TP536M-100B	1000(IEC)	100	18.4	5.43	22.6	5.76	
TP536M-95; TP536M-95B	1000(IEC)	95	18.2	5.22	22.5	5.56	
TP536M-90; TP536M-90B	1000(IEC)	90	17.7	5.08	22.4	5.38	
TP536M-85; TP536M-85B	1000(IEC)	85	17.6	4.83	22.3	5.26	



### **Headquarter**

Talesun Solar Co.,Ltd.  
1# Talesun Road, Shajiabang,  
Changshu, Suzhou, Jiangsu Province,  
P.R. China 215542  
Tel.: +86 400 885 1098  
Fax: +86 512 5290 6773  
E-Mail: sales@talesun.com  
Web: www.tailesun.com

### **European Head Office**

Talesun Solar Germany GmbH  
Central Tower Munich  
Landsberger Strasse 110,  
80339 Munich, Germany  
Tel.: +49 (0)89-189 177-0  
Fax: +49 (0)89-189 177-499  
E-Mail: sales.eu@talesun.com  
Web: www.tailesun-eu.com

### **USA**

Talesun Solar (USA)  
111W. Saint John Street, Suite 900,  
San Jose, CA 95113, USA  
Tel.: +1 800 276 0823  
Fax: +1 408 645 7111  
E-Mail: sales.USA@tailesun.com  
Web: www.tailesun.com

### **Switzerland**

Talesun Solar Switzerland AG  
c/o Muheim & Merz Bundesplatz 2  
6300 Zug, Switzerland

### **Singapore**

Talesun Solar (Singapore) Pte. Ltd.  
50 Kallang Avenue #01-02  
Singapore 339505

### **Hong Kong**

Talesun Solar Hong Kong Limited  
36/F, Tower Two, Times Square  
1 Matheson Street  
Causeway Bay, Hong Kong

